



Kit Trailer Owner's Manual

BEFORE USING YOUR TRAILER

Carefully read this manual and follow all these instructions before use

Save this manual for future use

For questions or to orders parts contact us

1-866-857-1445

www.westbrooktrailers.com

support@westbrooktrailers.com

Table of Content

Safety Information	4
Licensing the Trailer	6
Preparing to Tow	7
Coupling the trailer	8
Loading the Trailer	10
Trailer Towing Guide	13
Front & Rear Rail Options (8" Tire)	24
Front or Rear Rail Options (12" Tire)	25
Inspection and Scheduled Maintenance	26
Wheel Assembly	28
Axle, Hub and Bearing Assembly	30
Trailer Lights and Wiring	32
Warranty and Registration	35

Congratulations on the purchase of your new utility trailer.

This owner's manual is intended for Westbrook kit trailer. Safety is our number one concern. Before using your trailer, you must read, understand and follow the instructions provided by the tow vehicle, trailer hitch manufacturers, and the owner's manual.

Safety Information

Trailers are not generally used every day and may sit for extended periods of time between uses therefore is it important that you check all components thoroughly on the trailer before use.

Safety Check List:

- Make sure all lights are working correctly on the trailer and the towing vehicle
- Do not let children, people or pets ride in or on the trailer at any time; serious injury or death can occur
- Keep clear of moving parts. They can cause serious injury of death.
- Make sure all pins and bolts are in place and secure before usage
- A trailer will affect how the vehicle handles so always drive with care and never exceed the speed limit. Make sure to leave extra room between other vehicles for passing and breaking
- Never exceed the payload of the trailer or the towing vehicle. See trailer and vehicle owner's manuals. Use whichever rate is less.
- Make sure the load is centered over the axle with 10% forward of the axle to allow for tongue weight.
- Make sure the tongue weight is not more than 10% of the load.
- Secure load and check regularly during use.
- The trailer must be attached to the vehicle when loading and unloading.
- Check that your wheel nuts are torque to 95 lbs after the first 50 mil/80 km. and every 500 mi/800 km.
- Check the tire pressure (PSI) regularly; it should match the rating that is noted on the side of the tire wall.
- Wheel bearing should be checked and re-packed every 2000 miles or 3200 km. or every 12 months.
- Ball size on the vehicle must match the coupler size
- Make sure the coupler and ball are properly attached to each other and the coupler latch is closed
- Make sure the safety chains are crossed over each other and attached to the vehicle leaving slack in the chain to allow for turning
- Do not force the trailer to do a job it is not designed for. Know your trailer; learn its limitations and applications



Safety information is denoted by the safety alert symbol in the manual:

Hazards or practices which could result in severe personal injury or death if warning ignored.

Reporting Safety Defects

In Canada

If you believe your vehicle has a defect that could cause a crash or could cause injury or death, you should immediately inform Transport Canada in addition to notifying Westbrook Trailers Ltd. For best results, phone Transport Canada at (800) 333-0510 or (613) 993-9851 and ask to speak to a defect investigator. Calling directly is preferred instead of post-ed mail or email as it enables our investigators to confirm that your information is correct, and to answer your questions accurately.

When reporting a vehicle problem that may relate to safety, provide the following information:

Vehicle make, model, and year.

Owner's name, address, and daytime phone number.

Vehicle Identification Number (VIN) found on the driver side of the trailer frame.

Summary of the defect.

Information provided by the consumer is entered into the computer data bank and catalogued according to make, model, year, manufacturer, and the affected part, assembly or system. Technical staff conducts a continuous analysis of complaints and trends to determine whether an unusual number of complaints of potential safety-related problems have been received on any specific line of vehicles or tires and may open an investigation.

In USA

If you believe that your vehicle has a defect which could cause a crash or could cause injury or death, you should immediately inform the National Highway Traffic Safety Administration (NHTSA) in addition to notifying Westbrook Greenhouse Systems Ltd.

If NHTSA receives similar complaints, it may open an investigation, and if it finds that a safety defect exist in a group of vehicles, it may order a recall and remedy campaign. However, NHTSA cannot become involved in individual problems between you, your dealer, or Westbrook Greenhouse Systems Ltd.

To contact NHTSA, you may call the Vehicle Safety Hotline toll-free at 1-888-327-4236 (TTY: 1-800-424-9153); go to <http://nhtsa.safercar.gov>; or write to: Administrator, NHTSA, 1200 New Jersey Avenue SE, Washington, DC 20590. You can also obtain other information about motor vehicle safety.

Licensing the Trailer

Most provinces or states require that you license and title your trailer before you tow it. You are required to check with the Ministry of transportation (MOT) in Canada, or Department of motor vehicles (DOT) in US, with regards to licensing a trailer. Licensing laws will vary from province to province and state to state.

In Canada

Take the Bill of Sale and the completed New Vehicle Information Statement (NVIS) to the Ministry of Transportation . After paying the provincial fees, your trailer will be registered. At this time, you will be issued a trailer license plate. If you sell your trailer, you will need to sign the ownership to the new buyer. N.V.I.S. (New Vehicle Information Statement) (Canada Only).

In USA

Take the Bill of Sales and the completed Certificate of Origin to the Department of motor Vehicles, where after paying the state fees your trailer will be registered and/or titled. At this time you may also be issued a trailer license plate. If you sell the trailer you will need to transfer the certificate of origin to the new buyer. Certificate of Origin (C of O) (US only).

VIN Label

Your trailer has a 17 digit vehicle identification number. It is located on the VIN label on the driver's side of the trailer. This VIN number must be always be visible. The VIN label provides required information such as G.V.W.R., axle rating, payload, and tire and wheel ratings.

G.V.W.R This is the maximum allowable gross weight of your trailer and its contents. The gross weight of the trailer includes the weight of the trailer and all of the items within it.

VIN: This is the Vehicle Identification Number.

MANUFACTURED BY/FABRIQUE PAR: WESTBROOK GREENHOUSE SYSTEMS			DATE: Nov2014	
GVWR/PNBV: 908 KG (1998 LB)				
GVWR/PNBV:		TIRES/PNEU	RIMS/JANTE	COLD INFL. PRESS. /PRESS. DE CONF. A FROID
FRONT/ AVANT	1000 (2200LB)	ST175/80D13B	13 X 4.50 JB	241 KPA SINGLE DUAL
REAR/ ARRIERE	(LB)			35 PSI/LPC <input checked="" type="checkbox"/> SINGLE <input type="checkbox"/> DUAL
				KPA SINGLE DUAL
				PSI/LPC <input type="checkbox"/> SINGLE <input type="checkbox"/> DUAL

THIS VEHICLE CONFORMS TO ALL APPLICABLE U.S. FEDERAL MOTOR VEHICLE SAFETY STANDARDS IN EFFECT ON THE DATE OF MANUFACTURE SHOWN ABOVE.
THIS VEHICLE CONFORMS TO ALL APPLICABLE STANDARDS PRESCRIBED UNDER THE CANADIAN MOTOR VEHICLE SAFETY REGULATIONS IN EFFECT ON THE DATE OF MANUFACTURE. CE VEHICULE EST CONFORME A TOUTES LES NORMES QUI LUI SONT APPLICABLES EN VERTU DU REGLEMENT SUR LA SECURITE DES VEHICULES AUTOMOBILES DU CANADA EN VIGUEUR A LA DATE DE SA FABRICATION

V.I.N./N.I.V.: **2SSUB11A5BG000000** TYPE/TYPE: TRA/REM

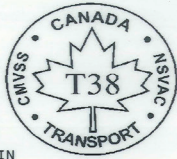

			
TIRE AND LOADING INFORMATION			
The weight of cargo should never exceed XXX kg. or XXX lbs.			
TIRE	SIZE	COLD TIRE PRESSURE	SEE OWNER'S MANUAL FOR ADDITIONAL INFORMATION
FRONT	20.5x8.0-10(E)	621KPA, 90PSI	
REAR			
SPARE	NONE		

Preparing to Tow

A reliable coupling of the trailer to the tow vehicle is essential to safety. Therefore, you must understand and follow all of the instructions for coupling.



Improperly coupled trailer may result in death or serious injury.

The following parts are involved in making a secure coupling between the trailer and the tow vehicle:

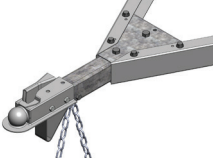

Coupler: A device on the tongue of the trailer that makes the connection to the hitch on the tow vehicle. All our trailers use a 1 7/8" coupler. The correct size will be stamped on the coupler.



Hitch: A device on the tow vehicle, to which the coupler of the trailer is attached. The hitch also supports the weight of the trailer tongue.



Safety Chains: They keep the trailer attached to the tow vehicle in case the coupler connection comes loose. In order to be effective, safety chains must be properly rigged to the trailer. With proper rigging, it is possible to keep the tongue of the trailer from digging into the pavement, even if the coupler to hitch connection comes apart. Safety chains are of standard length for the matching class of coupler. Taller or longer vehicle hitch packages may require additional chain or hardware to ensure correct length.



Trailer: Lighting Connector: A device that connects electrical power from the tow vehicle to the trailer. This connector allows vehicle to operate the brake lights, running lights, and turn signals as required.



Jack: An optional device on the trailer that is used to raise and lower the tongue (front) of the trailer. Jack is to assist in coupling the trailer only and cannot be used for in-trailer storage or materials without additional support. Trailer jack needs to be secured or removed before towing.

Do not move the trailer until:

- The coupler is secured and locked, if applicable
- The safety chains are secured to the tow vehicle
- The trailer jack has been secured or removed
- The trailer lights are properly connected and operational
- All rails need to be secured as per instruction sheet

Coupling the trailer

You are responsible for providing a vehicle and hitch that have a towing capacity that is sufficient for your trailer. Vehicle and hitch manufacturers are the appropriate source of competent advice. If the vehicle or hitch is not properly selected and matched, you can cause an accident that may result in loss of life.

Check list prior to coupling your trailer to tow-vehicle:

- Make sure the hitch ball size matches the coupler
- Check the hitch ball for wear, corrosion and cracks before coupling.
- Replace worn, corroded or cracked hitch ball before coupling the trailer.
- Make sure the hitch ball nut is tight before coupling the trailer.

Coupling the trailer to tow vehicle:

- Lower the trailer until the coupler fully engages the hitch ball. If the coupler does not line up with the hitch ball, adjust the position of the tow vehicle or trailer.
- Engage the coupler locking mechanism. In the engaged position, the locking mechanism holds the coupler securely to the hitch ball.
- Make sure that the coupler completely covers the hitch ball and the locking mechanism is engaged. A properly engaged locking mechanism will permit the coupler to raise the rear of the tow vehicle.

The coupler should be preset to fit on your 1 7/8" ball. If the coupler does not fit on the proper ball, first make sure the trailer and tow vehicle are on level ground. When the trailer or tow vehicle are not level the coupler will go on at an angle and may be difficult to attach. The coupler should close around the ball with some force. Do not tighten so the latch cannot be closed by hand and do not leave so loose that it can be closed with one or two fingers. Make sure the coupler is properly seated on the ball when testing the latch. Lift up on the tongue to make sure the coupler is properly seated on the ball.

Always make sure the coupler and safety chains are correctly attached to the towing vehicle!

The coupler latch must always be closed when towing the trailer!

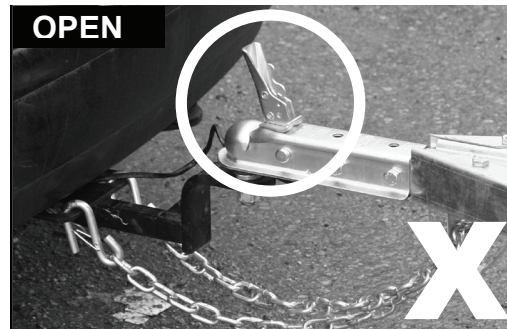
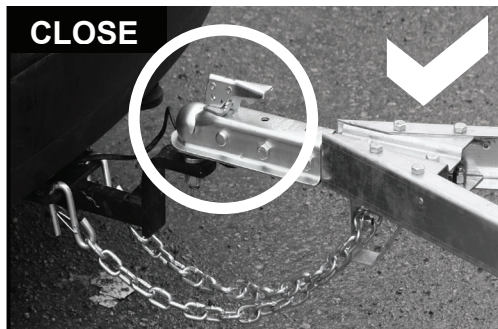
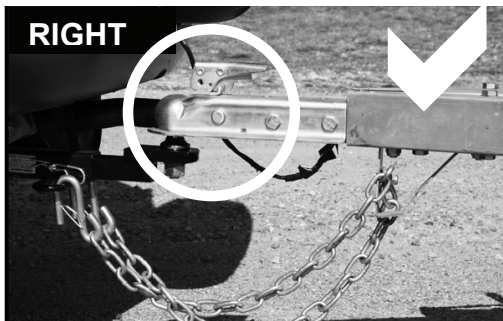

Use of an under-rated hitch or tow vehicle may result in loss of control leading to death or serious injury. A secure coupling, including the correct attachment of safety chains, is vital.

Adjusting the Coupler

- Have the trailer hooked up to the tow vehicle.
- Open the coupler latch
- To adjust how the latch closes you will have to adjust the nut on the bottom of the coupler. Turning the nut up will make it tighter, while turning the nut down will loosen the latch.

Uncoupling the Trailer

Follow these steps to uncouple your ball hitch trailer from the tow vehicle

- Before uncoupling the trailer, block the trailer tires to prevent the trailer from rolling.
- Disconnect the electrical connector
- Disconnect the safety chains from the tow vehicle
- Unlock the coupler.
- The trailer is now ready to be removed from your vehicle.

Ball Mount or Draw bar

This is the removable section of the vehicle's towing hitch, where the ball is mounted. There are various sizes with different drops and rises; you will want to use the size that will keep your trailer as level as possible.



Safety Chains

Safety chains are provided so that control of the trailer can be maintained, even if the trailer becomes loose from the hitch. To be effective, safety chains must be in good condition and properly rigged.

How to attach the Safety Chains

- The chains should be crossed over each other under the tongue before they are attached to the vehicle hitch.
- The chains should be attached to the loops on the frame of the tow vehicle either side of the hitch. Do not attached to the trailer hitch or ball
- The chains should not drag on the ground. If they do, disconnect them from the towing vehicle and cross them over each other until they are off the ground, then reattach them to the vehicle.
- There should be some slack to allow for turning.



Incorrect rigging of the safety chains may result in loss of control of the trailer and tow vehicle leading to serious injury or death.

Loading the Trailer

An improperly loaded trailer is dangerous on the road. Many accidents and deaths are caused by improper loading. Safely loading a trailer is an activity that requires attentions to many factors

- Overall load weight
- Load weight distribution
- Securing the load properly

Weight and Load Distribution

To determine that you have loaded the trailer within its rating, you must consider the distribution of weight, as well as the total weight of the trailer and its contents. The total weight of the trailer and its contents must never exceed the GVWR, as stated on the trailer's VIN tag. The G.V.W.R or Gross vehicle Weight Rating is the total weight including the weight of the trailer. Any accessories or other items that are attached to the trailer will increase the weight of the trailer. This extra weight must be deducted from the maximum payload.

Max Payload

Payload is indicated on trailer VIN and it should not exceeded for trailer.

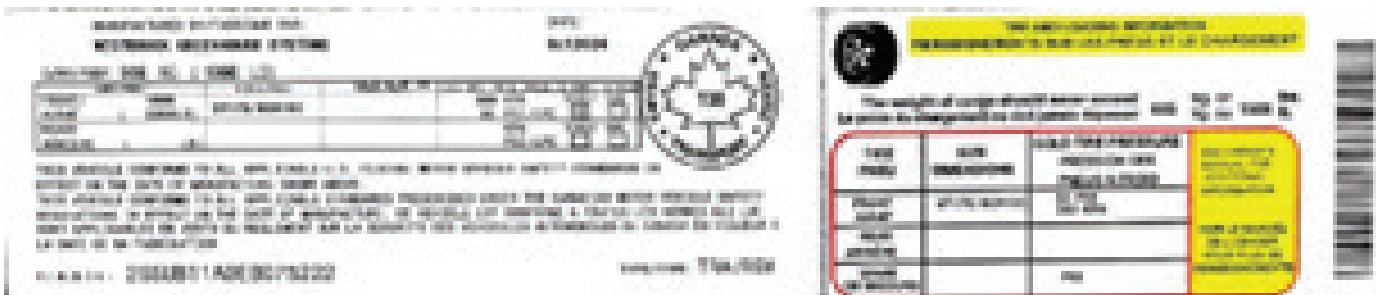

An overloaded trailer is very dangerous and can cause serious injury, death or damage. Always make sure your load is below the maximum payload rating.

Proper handling of your trailer depends on having the trailer load distributed properly. The trailer is more stable when its center of gravity is low and centered. This is essential to minimize the risk of tipping over.

You will need to distribute the load so that the tongue has enough weight to provide predictable handling, and so that no single tire is overloaded. The tongue weight is 10% of the load (excluding the weight of the trailer). The load is divided so that 90% of the load is over the axle and 10% on the tongue. The maximum tongue weight must not exceed 10% of the trailer GVWR. This is the downward pressure placed on the ball by the coupler and can be measured using a bathroom scale.

Loading Cargo

Before loading cargo into your trailer, inspect the trailer for any damage. The trailer must be coupled to the tow vehicle before loading. This is critical for the utility trailer; the tongue may rise during loading, before the cargo is properly distributed.

- Read the “Weight and Load distribution” section.
- Always ensure to load the trailer floor uniformly.
- Some loads are concentrated at only few points. Understand the load and place adequate reinforcements on the floor to prevent damage.
- Ensure to distribute heavy loads over the axle.
- Avoid overhanging loads.
- Never transport people or animals on your trailer. Besides putting their lives at risk, the transport of people in trailers is illegal.
- Do not use the trailer to transport flammable, explosive, poisonous or other dangerous materials.
- Do not use side rails as tie down points. Anchored it to the stack pockets.

Shifting Cargo

The user is responsible for securing cargo in such a way that it does not shift within the trailer during the tow. The cargo may be ejected onto the road if the rails are not secured.



A shifting load may result in failure, or loss of control of the trailer, and can lead to death or serious injury.

Before you begin your tow, double check all of these items:

- Coupler secured and locked
- Safety chains properly rigged to tow vehicle, not to hitch or ball
- Tire Pressure, tire tread and wear patterns. (No cuts, bulges, cracks or cords)
- Lug nuts for tightness
- Lights are functional
- Cargo appropriately restrained (ramps/rails are secured if equipped)

Regular Stops Checklist:

After each 80 KM (50 miles), or one hour of towing, stop and check the following items:

- Coupler is secure
- Safety chains are fastened and have not been dragging
- Tire pressure
- Cargo is secure
- Rails/ramps are securely fastened

When loading your trailer follow these simple rules:

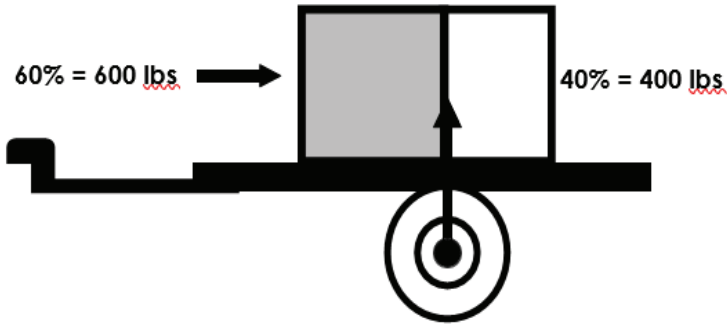

For proper trailer tongue weight, you should put about 60 percent of the load distributed evenly over the front half of the trailer and 40 percent of load distributed evenly on back of trailer.

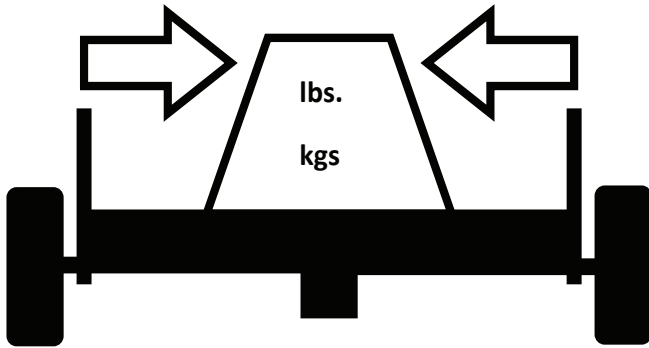

Always make sure the load is centered from side to side to balance the trailer.

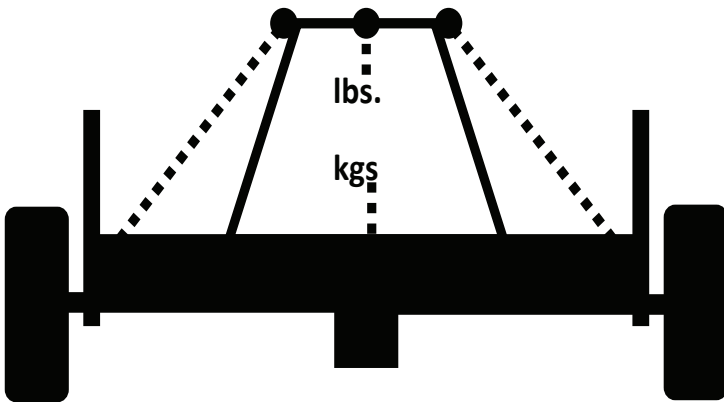

Always make sure the load is secured to the trailer

- Side to side
- Back to front

Example: Load of 1000 lbs

For instance, if 2,000-pound trailer is still carrying 1,000 pounds, roughly 600 pounds should be in the front half of the trailer evenly distributed and rest 400 pounds should be evenly distributed on back of trailer.

Trailer Towing Guide

Before towing the trailer, the user must follow all of the instructions for inspection, testing, loading and coupling. As with driving a car, towing a trailer is a learning experience. The hazards, however, are greater than when driving a vehicle without a trailer. Acceleration, manoeuvrability and braking are all diminished. It will take longer to get up to speed and more room is required to turn, pass and stop. The user is responsible for keeping his/her vehicle and the trailer under control, and for all of the damage that is caused if control is lost. Therefore, find an open area with little or no traffic for your first practice tow. Drive slowly at first, 8 km/hr (5 MPH) or less, and turn the wheel to get the feel for how the tow vehicle and trailer responds. Next, make some right and left hand turns and watch how the trailer responds in your rear view.

Guidelines :

- Before towing, check coupling, safety chains, tires, and lights. Check the lug bolts for tightness.
- Check the coupler tightness after towing 80 KM (50 miles).
- Adjust your mirror in order to see the trailer as well as the area to the rear of it.
- Use your mirrors to verify that you have room to change lanes or pull into traffic.
- Use your turn signals well in advance.
- Allow plenty of stopping space for your trailer and tow vehicle. Never drive faster than 100 km/h (60 MPH).
- Allow plenty of room for passing (a rule of thumb is that the passing distance with a trailer is 4 times the passing distance required without a trailer).
- Use a lower gear when going down steep or long grades. Do not ride the brakes, or they may overheat to the point of becoming ineffective. Use the engine and transmission as a brake.
- Do not ride the brakes while descending grades, they may overheat and stop working.
- To conserve fuel, don't use full throttle to climb a hill. Instead, build speed on the approach. Slow down for bumps in the road. Be off the brake when crossing the bump.
- Do not brake while in a curve unless absolutely necessary. Instead, slow down before you enter the curve and power through the curve. This way, the towing vehicle remains "in charge".
- Do not apply the brakes to correct extreme trailer swaying. Continued pulling of the trailer with a slight even acceleration, will provide a stabilizing force.
- Make regular stops, about once each hour. Confirm that the coupling is in order and locked, electrical connectors made. Also make certain that the tires are not visibly low on pressure, and that your cargo is secure and in good condition.



The maximum speed that the trailer can be safely towed, under ideal conditions, is 100 KM (60 miles) per hour. Do not exceed the maximum towing speed. Driving too fast for conditions may result in loss of control and cause death or serious injury. Reduce your speed when towing a trailer.

When towing the trailer, you will have: slower acceleration, increased stopping distance, increased turning radius (watch the inside corner), and longer distance to pass, due to slower acceleration and increased vehicle length. Also keep in mind the following information:

- Beware of slippery conditions. A tow-vehicle and trailer combination is more likely to be affected by slippery road surfaces than a tow vehicle without a trailer.
- Anticipate the trailer reaction to the air pressure wave caused by passing trucks and buses. This reaction is called "swaying".
- Use rear view mirrors frequently to observe both the trailer behaviour and traffic patterns.
- Use the engine and transmission as a brake.
- Keep the height of your trailer in mind, especially when approaching sheltered areas or trees.

Backing up the Trailer

This can be frustrating and difficult if done without practice or when in a hurry. Ensure to look behind the trailer to make sure that there are no obstacles before backing the trailer. Avoid tight turns. Turning too tightly will cause the trailer to hit the rear of your vehicle and cause damage. To straighten the rig, either pull forward, or turn the steering wheel in the opposite direction. Adjust the vehicle steering wheel to make trailer straight to backing up.



Item#500814
3/8 U-Bolt

Item#501049
3/8 x 3/4
Hex Flange Bolt



Item#501033
3/8 x 1-1/2
Hex Bolt



Item#501036
3/8 x 3/4
Carriage Bolt



Item#501031
3/8 Locking Nut



Item#501032
3/8 Flat Washer

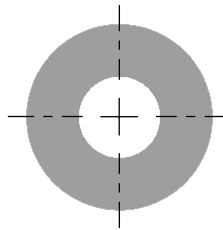

Item#501023
3/8 x 2-1/2
Hex Bolt



Item#501024
3/8 x 3
Hex Bolt

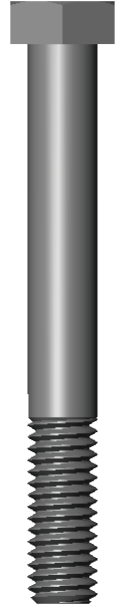

Item#501073
1/4 x 3/4
Hex Bolt



Item#501179
3/8X6-16 Eyebolt
Zinc Plated



Item#501060
1/2 x 3-1/2
Hex Bolt



Item#501065
9/16 x 3 UNF
Hex Bolt



Item#501056
1/2 Locking Nut



Item#501066
9/16 UNF
Locking Nut



Item#501101
1/2 Wheel Nut



Item#501181
#10 X 3/4
Pan Head Screw



Item#501091
#10 x 1/2 Phillips
Machine Screw



Item#501092
#10 Locking Nut



Item#501100
5/16 x 1/2
Cutting Screw



Item#501177
#10 X 3/4 Self-drilling
Pan Head Screw



Item#501081
1/4 Nylon Insert
Locking Nut



Item#501180
3/8 Knob Nut
4 Arm



Item#501094
#14 X 1/2 Tapping
Screw Pan Head



Item#501176
3/8X4 Hitch Pin
with R-Clip Clear Zinc



KIT TRAILER HARDWARE		
Item#	Description	Part number
1	3/8-16 U-BOLT	500814
2	3/8-16 X 2-1/2" HEX BOLT	501023
3	3/8-16 X 3" HEX BOLT	501024
4	3/8-16 NYLON INSERT HEX FLANGE LOCKNUT	501031
5	3/8" FLAT WASHER	501032
6	3/8-16 X 1 1/2" HEX BOLT	501033
7	3/8-16 X 3/4" CARRIAGE BOLT	501036
8	3/8-16 X 3/4" HEX FLANGE BOLT	501049
9	1/2-13 NYLON INSERT LOCKING NUT	501056
10	1/2-13 X 3 1/2" HEX BOLT	501060
11	9/16-18 UNF X 3" HEX BOLT	501065
12	9/16-18 UNF NYLON INSERT LOCKING NUT	501066
13	1/4-20 X 3/4" HEX BOLT	501073
14	1/4-20 NYLON INSERT LOCKING NUT	501081
15	10-24 X 1/2" PHILLIPS #2 MACHINE SCREW	501091
16	10-24 NYLON INSERT LOCKING NUT	501092
17	5/16-18 UNC X 1/2" CUTTING SCREW WITH	501100
18	1/2" NF PRESS IN WHEEL STUD	501101
RAIL SIDES HARDWARE		
19	3/8-16 X 3/4" HEX FLANGE BOLT	501049
20	3/8-16 X 2-1/2" HEX BOLT	501023
21	3/8-16 NYLON INSERT HEX FLANGE LOCKNUT	501031
22	#14 X 1/2" TAPPING SCREW PAN HEAD	501094
23	3/8X4IN BENT HITCH PIN CLEAR ZINC	501176
24	3/8X6-16IN EYEBOLT FOR RAMP ZINC	501179
25	3/8 KNOB NUT 4 ARM FOR RAMP	501180
FLOOR HARDWARE		
26	#10 X 3/4 IN SELF-DRILLING PAN HEAD SCREW	501177
27	#10 X3/4 IN PAN HEAD SCREW ZINC	501181
28	3/8-16 X 3/4" HEX FLANGE BOLT	501049

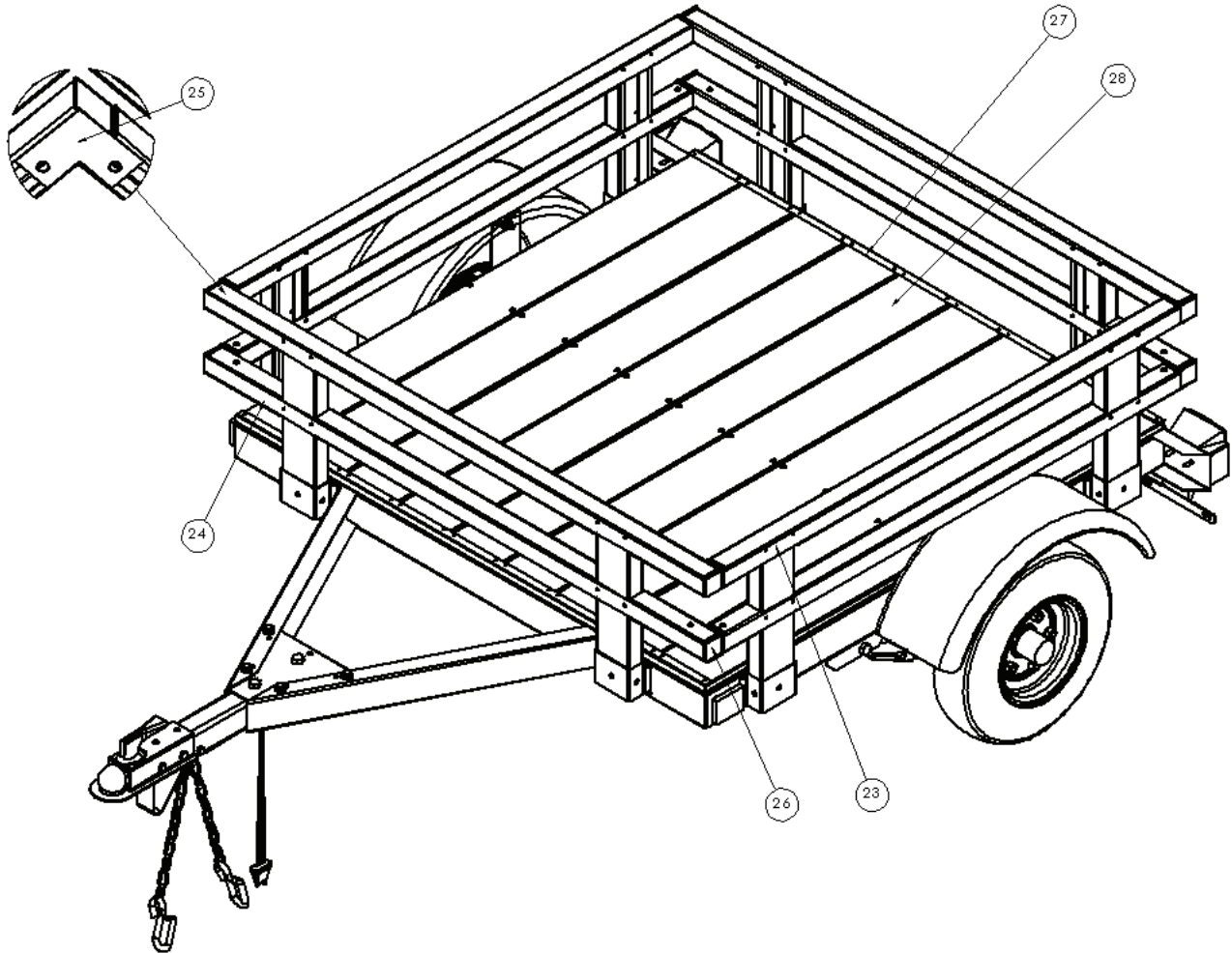
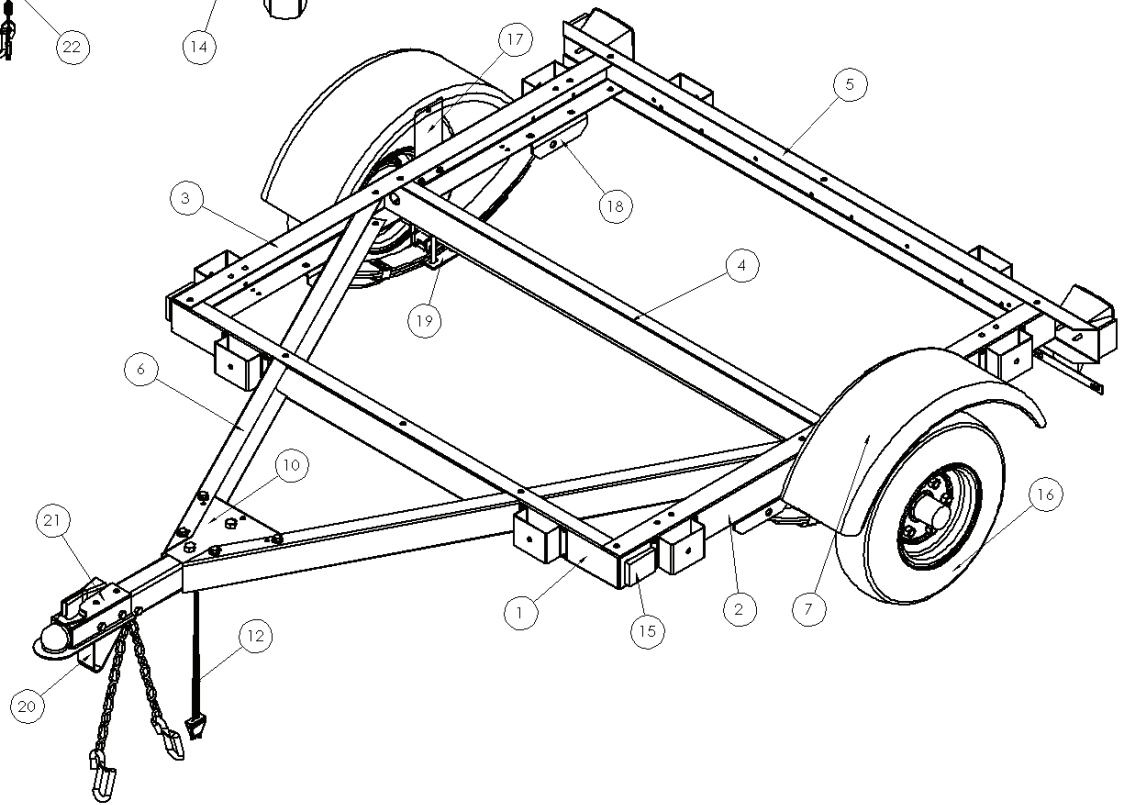
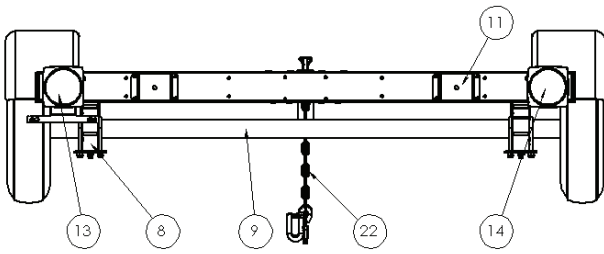

4' x 4' FLATBED KIT TRAILER

Item#	Description	4'X4' TRAILERS
1	FRONT CROSS CHANNEL	500254
2	4' OUTER CHANNEL_DS	500251
3	4' OUTER CHANNEL_PS	500297
4	CROSS CHANNEL	500255
5	REAR CROSS CHANNEL	500256
6	TONGUE CHANNEL	500257
7	FENDER	500258
8	LEAF SPRING (750 LBS)	504395
9	AXLE (1500 LBS.)	500047
10	TONGUE CONNECTION BRACKET	504162
11	STAKE POCKETS	504471
12	MAIN WIRE HARNESS	Refer to WIRING DIAGRAM on page
13	STOP/TURN LIGHT DS WITH LICENSE PLATE BRACKET	
14	STOP/TURN LIGHT PS	
15	AMBER MARKER LIGHT	
16	TIRE AND WHEEL ASSY.	
16	TIRE AND WHEEL ASSY.	500841
17	FENDER PLATE	504447
18	LEAF SPRING MOUNTING BRACKET	500259
19	LEAF SPRING AXLE MOUNT PLATE	500260
20	TONGUE SUPPORT FOOT	504198
21	COUPLER	500805
22	SAFETY CHAIN	500804
RAIL SIDES		
23	SIDE RAIL	504684
24	FRONT/BACK RAIL	504674
25	L BRACKET	501033
26	1.75" SQUARE TUBE CAP	501175
FLOOR		
27	4FT U CHANNEL FOR FLOOR PLANK	504736
28	4X4 KIT TRAILER GALVALUME FLOOR PLANK	504738

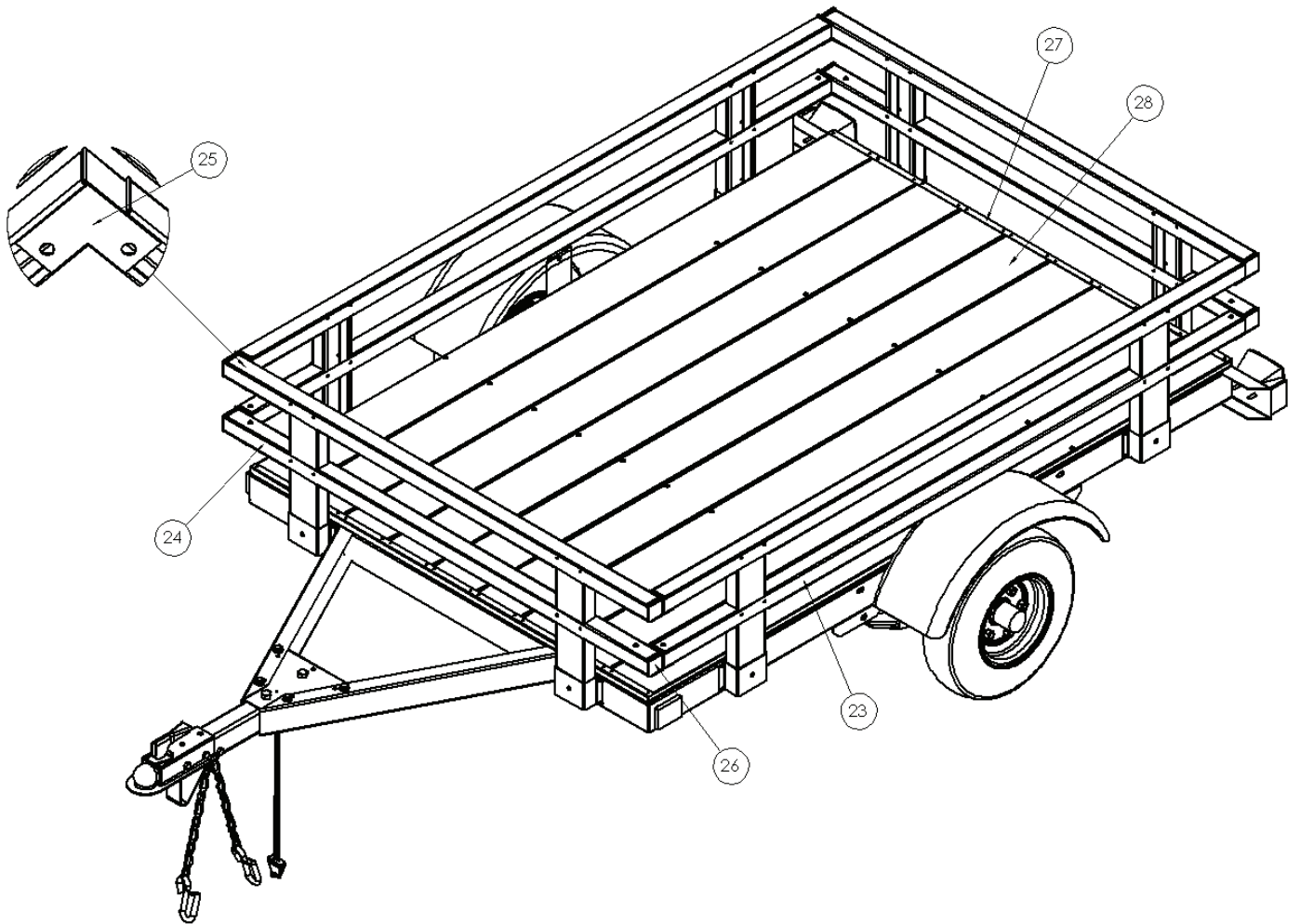
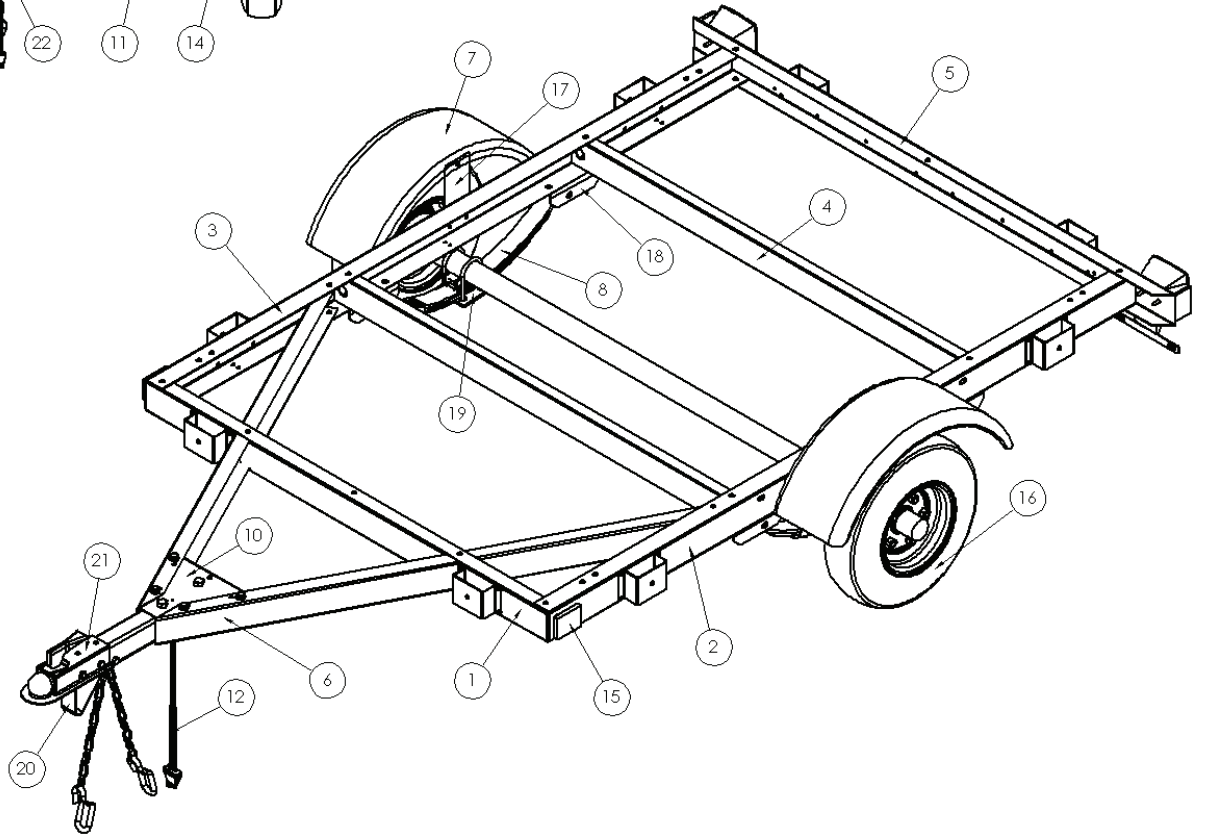
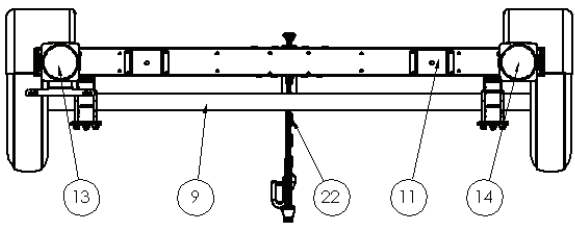

4' x 6' FLATBED KIT TRAILER

Item#	Description	4'X6' TRAILERS
1	FRONT CROSS CHANNEL	500254
2	6' OUTER CHANNEL_DS	500252
3	6' OUTER CHANNEL_PS	500298
4	CROSS CHANNEL	500255
5	REAR CROSS CHANNEL	500256
6	TONGUE CHANNEL	500257
7	FENDER	504258 (8" TIRE) 504212 (12" TIRE)
8	LEAF SPRING (750 LBS)	504395
9	AXLE (1500 LBS.)	500047
10	TONGUE CONNECTION BRACKET	504162
11	STAKE POCKETS	504471
12	MAIN WIRE HARNESS	Refer to WIRING DIAGRAM on page
13	STOP/TURN LIGHT DS WITH LICENSE PLATE BRACKET	
14	STOP/TURN LIGHT PS	
15	AMBER MARKER LIGHT	
16	TIRE AND WHEEL ASSY.	500841 (8" TIRE) 500844 (12" TIRE)
17	FENDER PLATE	504447
18	LEAF SPRING MOUNTING BRACKET	500259
19	LEAF SPRING AXLE MOUNT PLATE	500260
20	TONGUE SUPPORT FOOT	504198
21	COUPLER	500805
22	SAFETY CHAIN	500804
RAIL SIDES		
23	SIDE RAIL	504680 (8" TIRE) 504708 (12" TIRE)
24	FRONT/BACK RAIL	504674
25	L BRACKET	501033
26	1.75" SQUARE TUBE CAP	501175
FLOOR		
27	4FT U CHANNEL FOR FLOOR PLANK	504736
28	4X6 KIT TRAILER GALVALUME FLOOR PLANK	504739

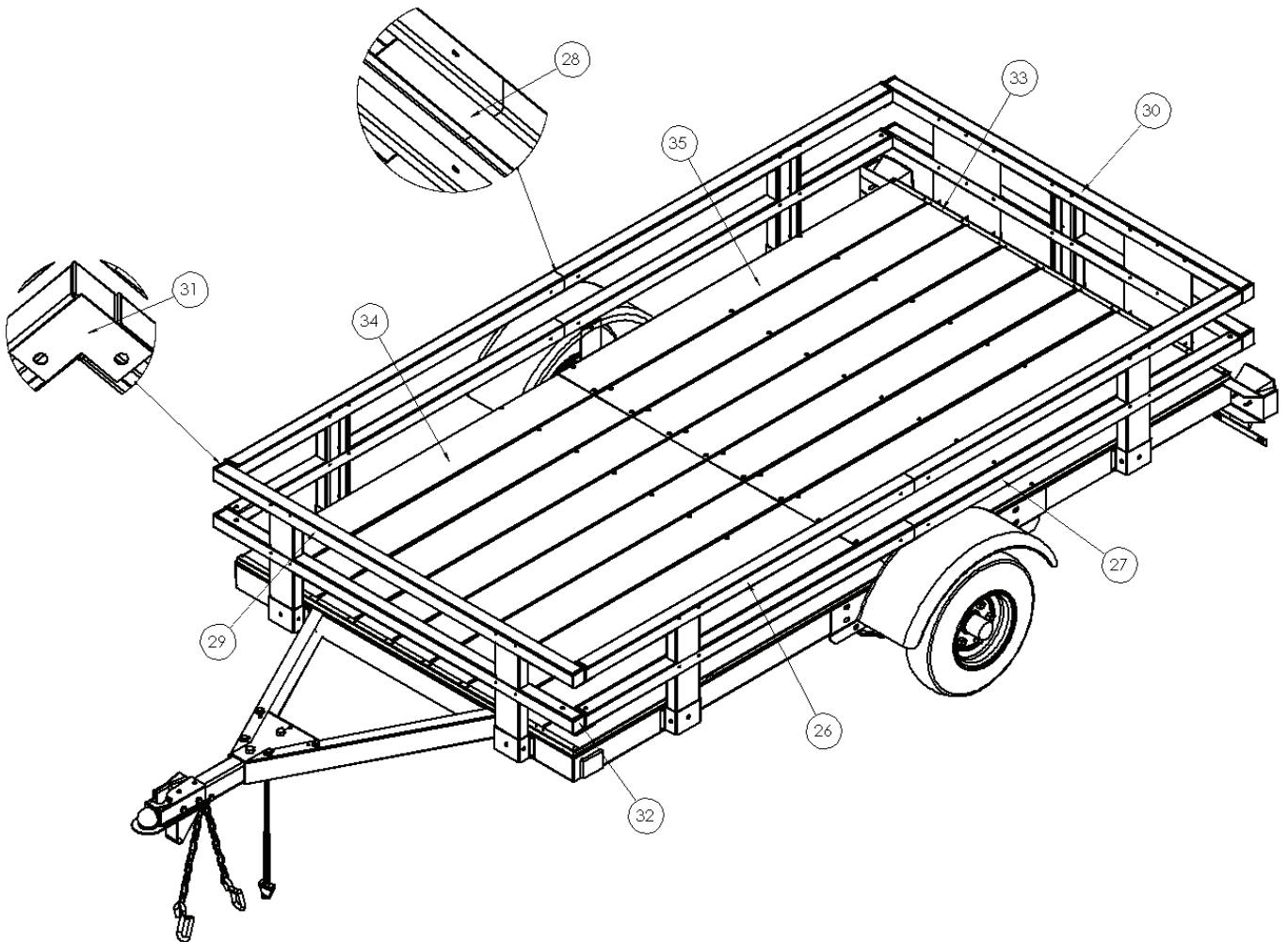
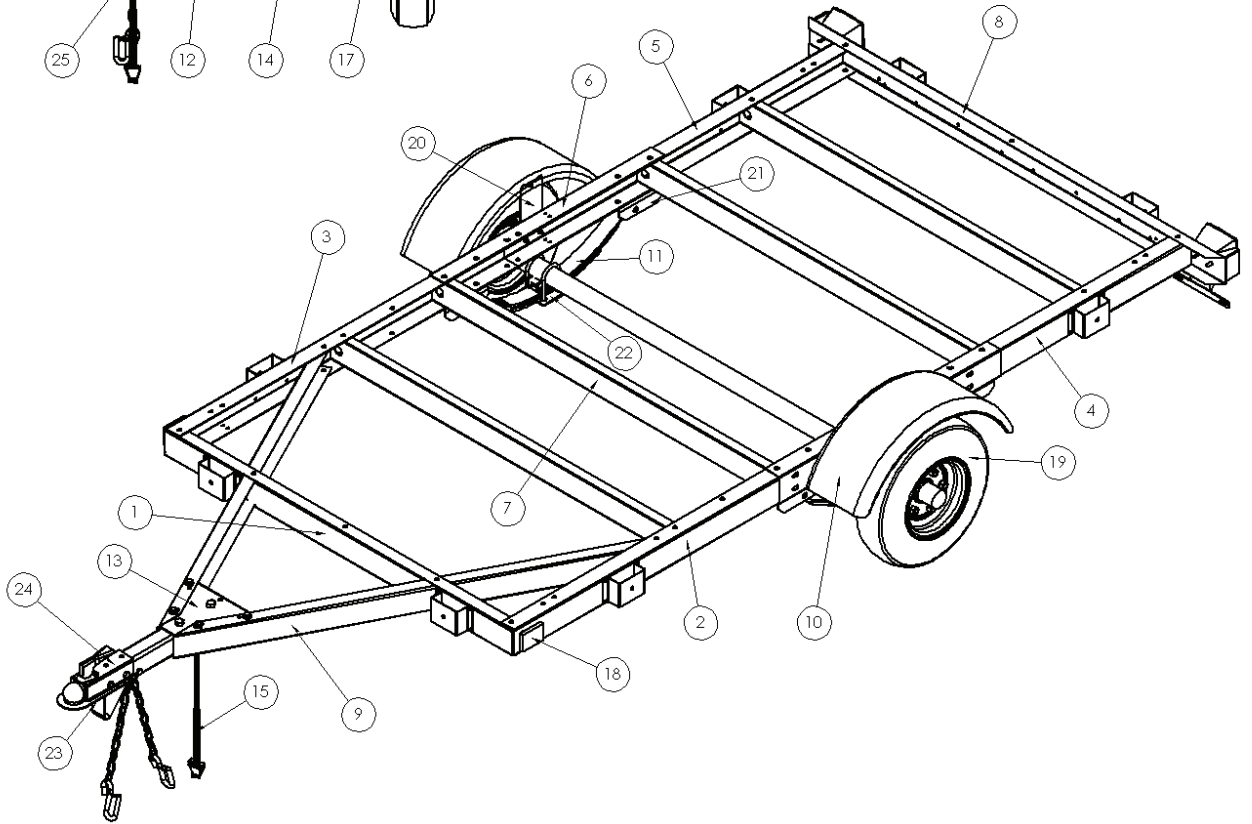
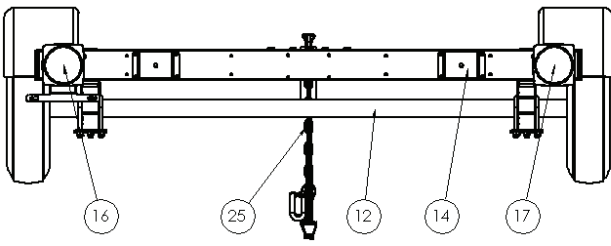

4' x 8' FLATBED KIT TRAILER

Item#	Description	4'X8' TRAILERS
1	FRONT CROSS CHANNEL	500254
2	4' OUTER CHANNEL FRONT_DS	500253
3	4' OUTER CHANNEL FRONT_PS	500300
4	4' OUTER CHANNEL REAR_DS	500299
5	4' OUTER CHANNEL REAR_PS	500301
6	OUTER CONNECTION CHANNEL	500272
7	CROSS CHANNEL	500255
8	REAR CROSS CHANNEL	500256
9	TONGUE CHANNEL	500257
10	FENDER	504258 (8" TIRE) 504212 (12" TIRE)
11	LEAF SPRING (750 LBS)	504395
12	AXLE (1500 LBS.)	500047
13	TONGUE CONNECTION BRACKET	504162
14	STAKE POCKETS	504471
15	MAIN WIRE HARNESS	Refer to WIRING DIAGRAM on page
16	STOP/TURN LIGHT DS WITH LICENSE PLATE BRACKET	
17	STOP/TURN LIGHT PS	
18	AMBER MARKER LIGHT	
19	TIRE AND WHEEL ASSY.	500841 (8" TIRE) 500844 (12" TIRE)
20	FENDER PLATE	504447 (8" TIRE) 504476 (12" TIRE)
21	LEAF SPRING MOUNTING BRACKET	500259
22	LEAF SPRING AXLE MOUNT PLATE	500260
23	TONGUE SUPPORT FOOT	504198
24	COUPLER	500805
25	SAFETY CHAIN	500804
RAIL SIDES		
26	8' FRONT SIDE RAIL	504675 (8" TIRE) 504667 (12" TIRE)
27	8' REAR SIDE RAIL	504676 (8" TIRE) 504670 (12" TIRE)
28	8' RAIL SIDE CONNECTION PART	504673
29	FRONT/BACK RAIL	504659 (8" TIRE) 504710 (12" TIRE)
30	RAMP RAIL GATE	504701 (8" TIRE) 504707 (12" TIRE)
31	L BRACKET	501033
32	1.75" SQUARE TUBE CAP	501175
FLOOR		
33	4FT U CHANNEL FOR FLOOR PLANK	504736
34	8' KIT TRAILER GALVALUME FRONT FLOOR PLANK	504740
35	8' KIT TRAILER GALVALUME REAR FLOOR PLANK	504741

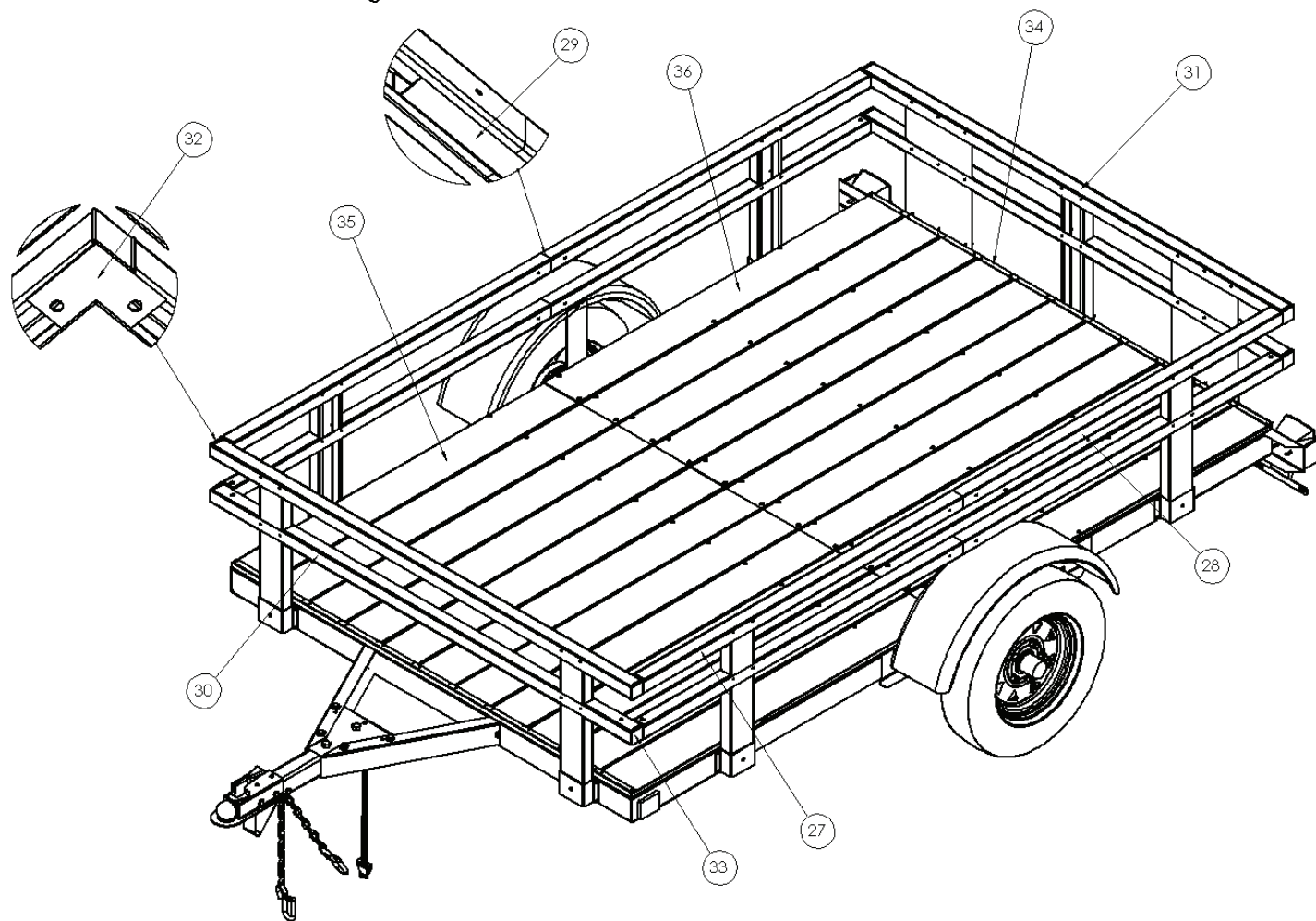
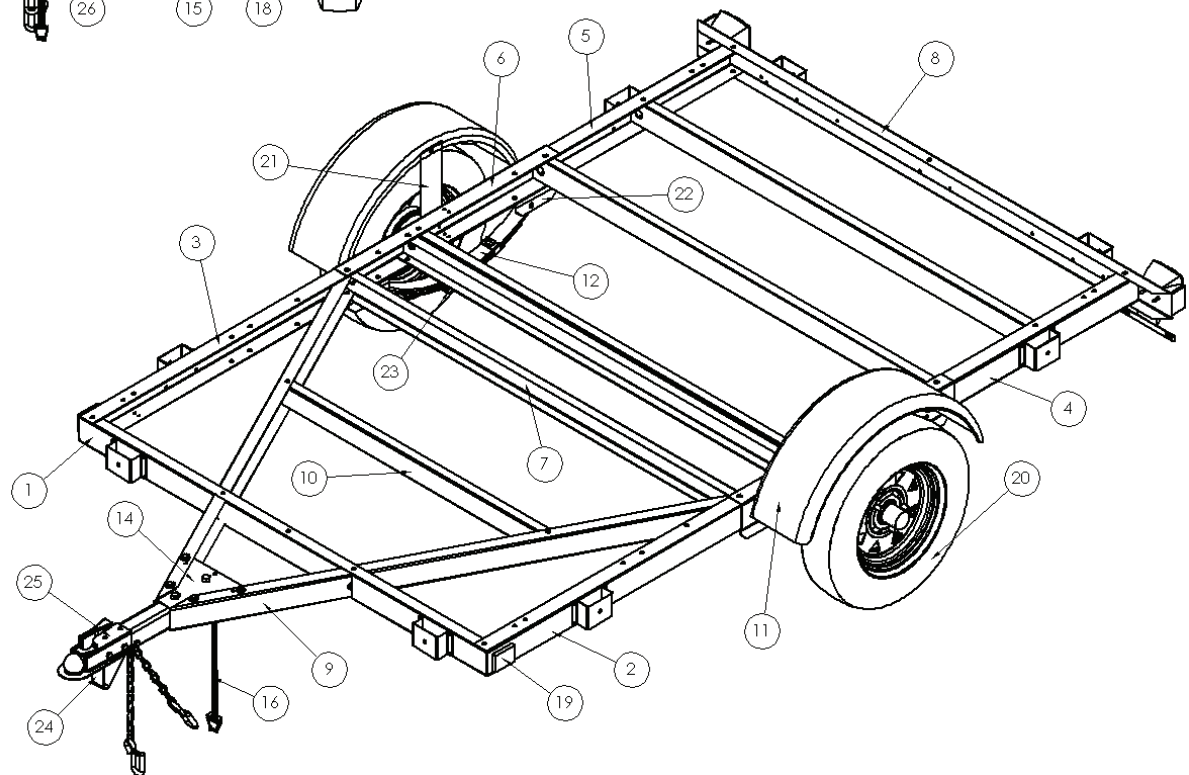
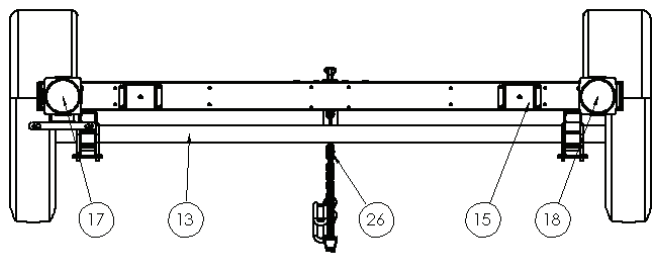

5' x 8' FLATBED KIT TRAILER

Item#	Description	5'X8' TRAILERS
1	FRONT CROSS CHANNEL	504599
2	4' OUTER CHANNEL FRONT_DS	500253
3	4' OUTER CHANNEL FRONT_PS	500300
4	4' OUTER CHANNEL REAR_DS	500299
5	4' OUTER CHANNEL REAR_PS	500301
6	OUTER CONNECTION CHANNEL	500272
7	CROSS CHANNEL	504602
8	REAR CROSS CHANNEL	504600
9	TONGUE CHANNEL	504601
10	TONGUE CROSS CHANNEL	504623
11	FENDER	504212
12	LEAF SPRING (750 LBS)	504395
13	AXLE (2000 LBS.)	504617
14	TONGUE CONNECTION BRACKET	504162
15	STAKE POCKETS	504471
16	MAIN WIRE HARNESS	Refer to WIRING DIAGRAM on page
17	STOP/TURN LIGHT DS WITH LICENSE PLATE BRACKET	
18	STOP/TURN LIGHT PS	
19	AMBER MARKER LIGHT	
20	TIRE AND WHEEL ASSY.	500844
21	FENDER PLATE	504476
22	LEAF SPRING MOUNTING BRACKET	500259
23	LEAF SPRING AXLE MOUNT PLATE	500260
24	TONGUE SUPPORT FOOT	504198
25	COUPLER	500805
26	SAFETY CHAIN	500804
RAIL SIDES		
27	8' FRONT SIDE RAIL	504667
28	8' REAR SIDE RAIL	504670
29	8' RAIL SIDE CONNECTION PART	504673
30	FRONT/BACK RAIL	504690
31	RAMP RAIL GATE	504693
32	L BRACKET	501033
33	1.75" SQUARE TUBE CAP	501175
FLOOR		
34	5FT U CHANNEL FOR FLOOR PLANK	504737
35	8' KIT TRAILER GALVALUME FRONT FLOOR PLANK	504740
36	8' KIT TRAILER GALVALUME REAR FLOOR PLANK	504741

Front & Rear Rail Options (8" Tire)

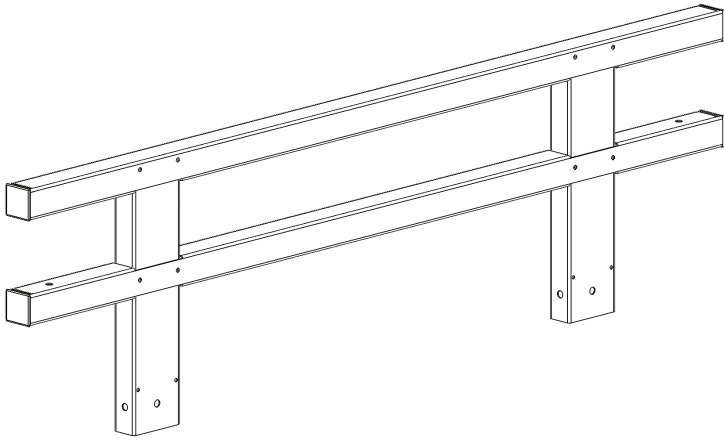

4' - 15" FRONT/REAR RAIL SIDE (504659)

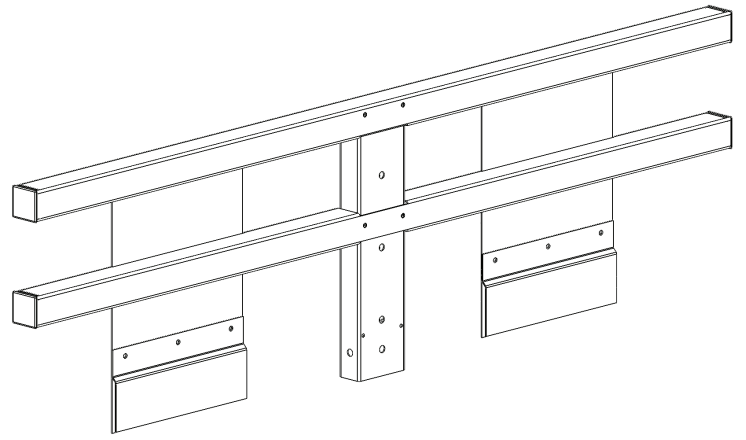

4' - 15" REAR RAMP RAIL SIDE (504662)

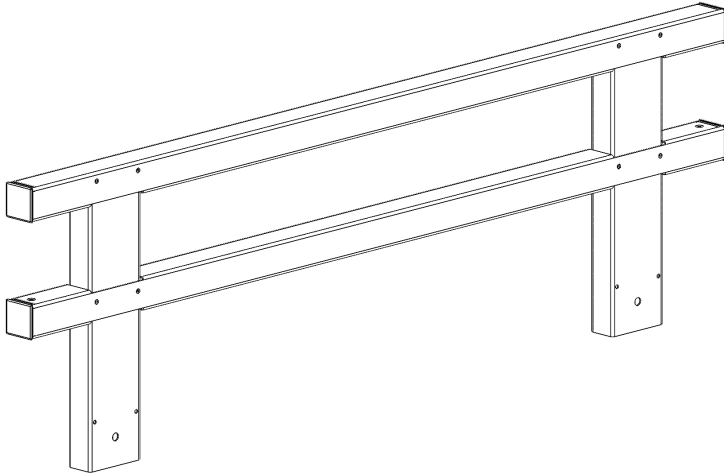

4X4 KIT TRAILER - 15" RAIL SIDE (504685)

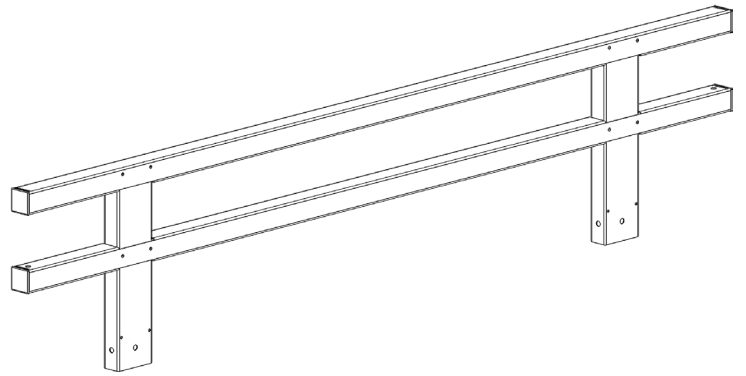

6' KIT TRAILER - 15" RAIL SIDE (504677)

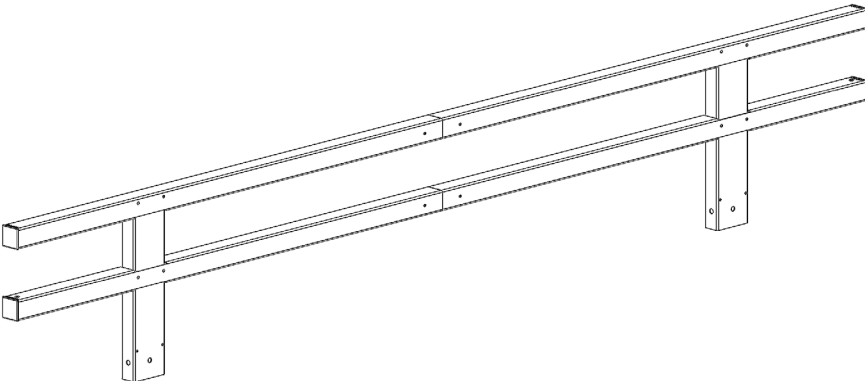

8' KIT TRAILER - 15" RAIL SIDE (504717)

Front or Rear Rail Options (12" Tire)

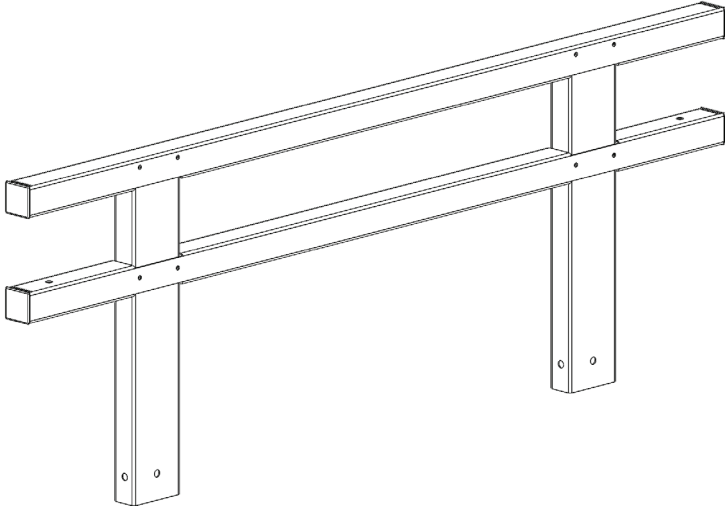

4' - 19" FRONT/REAR RAIL SIDE (504718)

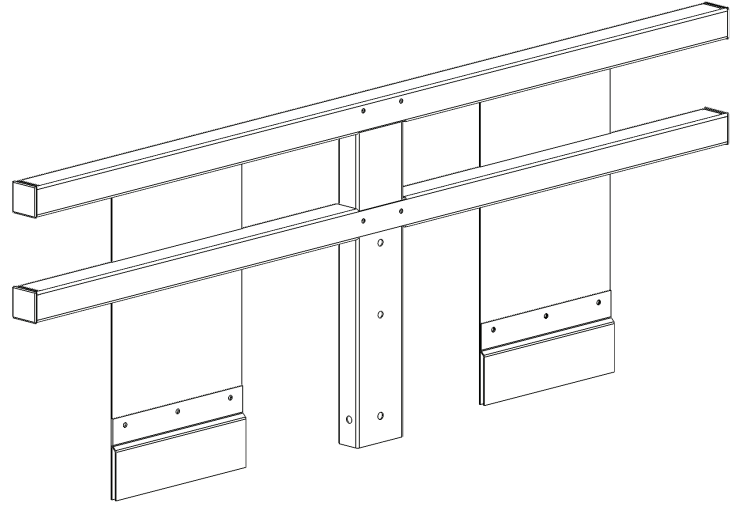

4' - 19" REAR RAMP RAIL SIDE (504711)

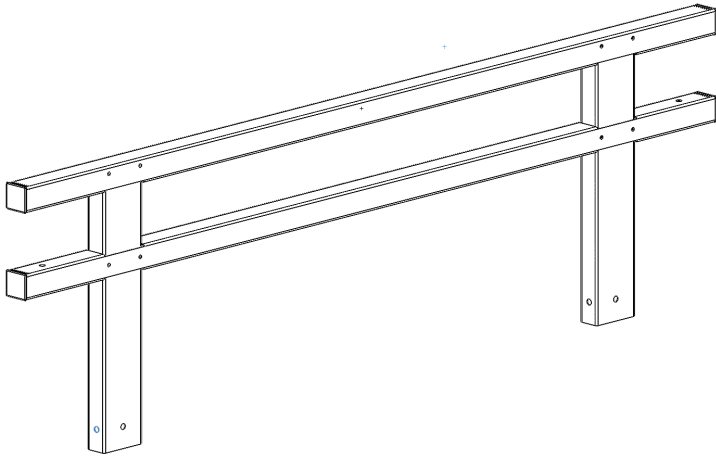

5' - 19" FRONT/REAR RAIL SIDE (504690)

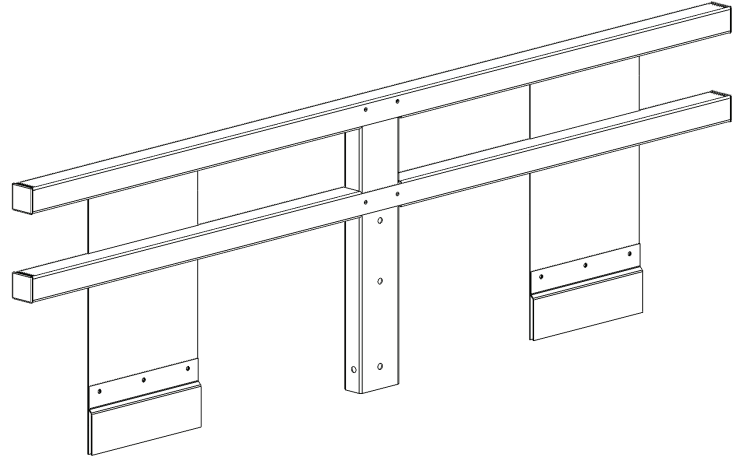

5' - 19" REAR RAMP RAIL SIDE (504693)

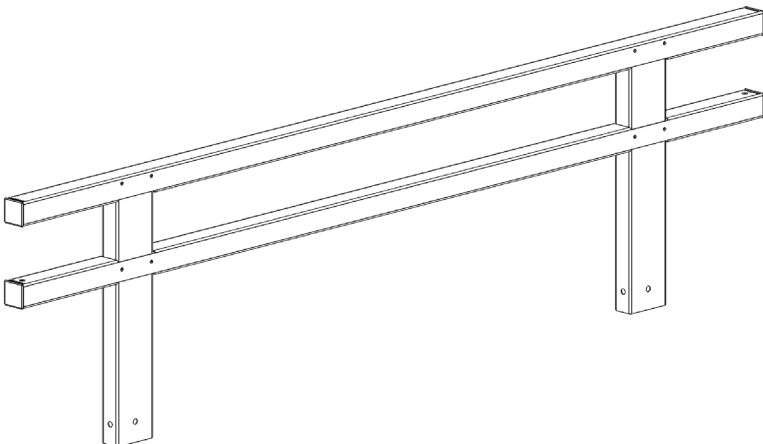

6' KIT TRAILER - 19" RAIL SIDE (504751)

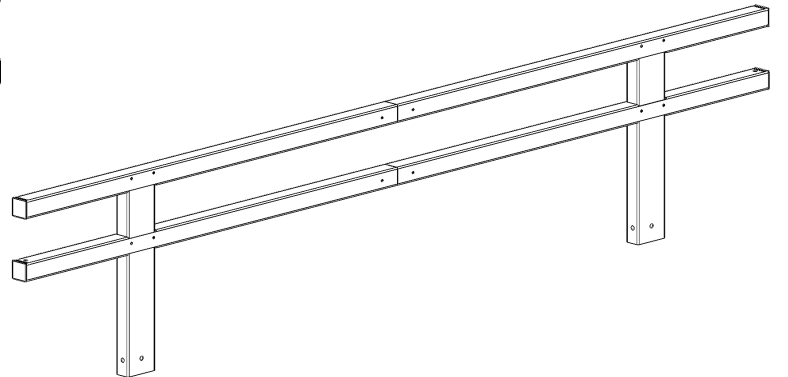

8' KIT TRAILER - 19" RAIL SIDE (504709)

Inspection and Scheduled Maintenance

Proper attention to scheduled maintenance must be followed to ensure safety of persons and essential to the longevity of the trailer. Various inspection and maintenance activities require that the trailer be jacked up. Please use the following precautions:

- Worn or broken suspension parts may cause loss of control resulting in death or serious injury. Have the trailer professionally inspected annually and after any impact.
- When jacking and using jack stands, place them clear of wiring and suspension parts. Place jacks and stands inside the perimeter strip on the supporting structure to which the axles are attached.
- Never crawl under your trailer unless it is on level ground and resting on properly placed and secured jack stands.

A recommended list of tools that may be applicable to scheduled maintenance and inspections is listed below:

Equipment	Tool
Coupler	3/4" Socket Wrench
Tire Wheel Nuts	13/16" Socket Wrench, Jack Stand
Fender Bolts	9/16" Socket Wrench
Axle Bolts	3/4" Socket Wrench
Rail side bolts	9/16" Socket Wrench

Trailer Connection to Tow Vehicle

The coupler on the trailer connects to the ball attached to the hitch on the towing vehicle. The coupler, ball and hitch transmit the towing forces between the tow vehicle and trailer. To reduce wear and ensure proper operation, coat the ball with a thin layer of automotive bearing grease before each use of the trailer.

- Check the locking device on the coupler and make sure that it operates properly. If you see or can feel evidence of wear, such as flat spots, deformations, pitting or corrosion, on the ball or coupler, replace before towing the trailer. Replace ball only with one having a load rating that matches or exceeds the GVWR of the trailer.
- The coupler handle lever must be able to rotate freely and automatically snap into the latched position. Oil the pivot points, sliding surfaces and spring ends with SAE 30W motor oil. Keep the ball pocket and latch mechanism clean.

Trailer Structure

To prevent severe damage to your trailer, you must inspect the frame structure for cracks or failure any time you know or suspect that your trailer has been subjected to an impact load. Do not attempt to repair a cracked or broken structure unless you have the skills and equipment for a proper repair. Improper repair may lead to early failure of the trailer structure and serious injury or death.

- Fasteners and Frame Structures – These are to be inspected for bending, damage, cracks or failure. Broken or damaged fasteners may cause injury or damage to trailer and contents. Inspect for and repair all damaged parts at least once a year.
- The frame structure can crack or fail when subjected to a heavy impact, such as can be delivered by collisions or movement of unsecured cargo.

Galvalume plus™ Steel Maintenance

Galvalume plus™ trailers is a specialized combination of 55% aluminum, 43.5% zinc and 1.5% silicone topped with a clear acrylic coating. When the barrier protection and long-term durability of aluminum are combined with the sacrificial protection of zinc, the result is optimal protection.

- Avoid direct contact with dissimilar metals, such as brass and copper. Where dissimilar metals are to be used together ensure that there is an insulator between metal and the galvanized products.
- Avoid long term storage of any galvanized product in damp and poorly ventilated conditions. Ensure the storage location is dry and there is effective ventilation.
- Avoid leaving any organic substance, wood or pressure treated wood on the trailer for an extended period of time. The chemical used in pressure treated wood is corrosive when in contact with metal parts, particularly to galvanized steel, moisture trapped underneath will cause oxidation of the galvanized steel.

Cleaning the Trailer

Wash the trailer with water only. Do not wash with harsh chemicals or solvent as they may stain the trailer. However, many mild stains can be removed with the use of common household ammonia cleansers, make sure to thoroughly rinse with freshwater afterwards. Any residues can cause discoloration later and/or encourage corrosion.

Wintering the Trailer

Please use the following precaution when storing your trailer for the winter months:

- Remove and wash any debris off the bed of the trailer before storing your it. If left outside, ensure that any snow accumulation doesn't exceed the recommended payload of your trailer.
- Use concrete blocks under the frame of the trailer to take the weight off the tires. If not, flat spots may develop that would weaken your tires. Reduce the air to the recommended cold weather PSI. The best option would be to remove the tires and store them on their sides in a flat and dry area. This may be a good reminder to repack your bearings in the spring.
- To prevent water from running between the trailer frame and the wood floor, apply a sealant to the pressure-treated wood before installation.

Wheel Assembly

Trailer tire and wheels are more likely to fail than car tires and wheels because they carry a heavier load. Therefore, it is critical that you develop the necessary habit of always inspecting the trailer tires before towing. Proper tire care and safety is important.

Before each use check the following:

- **Tire Pressure:** Improper tire pressure causes an unstable trailer. Verify the tire pressure is at the value indicated on the sidewall. A tire can lose up to half of its air pressure and not appear to be flat. Tire pressure must be checked while the tire is cold. If the trailer has been towed as much as one kilometre, allow at least three hours for the tires to cool.
- **Treads:** If the tires have too little tread, they will not provide adequate traction on wet roadways. If the tire treads have less than 1/16" depth or the telltale wear bands show, replace the tire before towing.
- **Side Wall:** Inspect both sidewalls of each tire for bubbles, cuts or bulges. Uneven tread wear may be caused by tire imbalance or improper inflation. Such conditions may lead to a tire blowout. Replace any damaged tire before towing.
 - ***Worn, damaged or under-inflated tires may result in loss of control of the vehicle, serious injury death or property damage may occur.***
- **Lug Nuts :** Lug nuts or bolts may shift and settle quickly after assembly. You must check the lug nuts for tightness after the first 16, 40 and 80 KM (10, 25, and 50 miles) of driving a new trailer (or remounted wheel), and before each tow thereafter. Trailer wheels and lug nuts are subjected to greater side loads than automobile wheels. This may cause the lug nuts to become loose. Failure to perform this check may result in a wheel parting from the trailer, and a crash leading to death or serious injury.
 - ***Inadequate lug nut torque may cause a wheel to part while towing. Death or serious injury can result.***

Replacing the Wheel Assembly

Assembly of the wheel onto the hub is a critical, safety-related process. The proper method of assembly and the consistency of the torque applied to wheel fasteners are important factors in ensuring reliability of the fastening system and retention of the wheel to the trailer. Torque is the measure of the amount of tightening applied to a fastener (nut or bolt) and is expressed as length force. For example, a force of 90 lbs applied at the end of a wrench 1 ft. long will yield 90 ft-lbs torque. Torque wrenches are the best way to assure the proper amount of torque is being applied to a fastener. The trailer end user must consistently follow proper torquing technique in order to ensure the hub and wheel are properly seated and use caution to prevent anything from interfering with the flat, full designed mating contact of wheel mounting surface and hub. Excess paint, oil and grease must be removed from the fastener contact surfaces (the mounting surfaces, studs, and lugs nut) or not applied at all. Adherence to all instructions, warnings and procedures set out below will minimize the likelihood of fastener torque-loss and wheel separation.

Instruction Cautions

- Surfaces of contact on a steel wheel (the nut seat and the mounting surface) must be free of excessive paint, contamination and damage. Smooth, clean surfaces provide the most uniform clamping pressure and best retain torque.
- Surfaces of contact on the axle (the flat hub surface and the threaded studs) must be free of excessive paint, oils, grease, contamination and physical damage.
- Lug nut geometry must match that of the wheel nut seat. The threads and nut seat must be free of paint, oils, grease, and other contamination.
- Stud length must be sufficient that after mounting the wheel to the hub, the lug nut is engaged to a depth at least equivalent to the diameter of the stud. For example, a lug nut threaded on a 1/2 inch diameter stud should thread on for a depth of at least 1/2 inch.

Torque Procedures

- Start all bolts or nuts by hand to prevent cross threading.
- Tighten bolts or nuts in the sequence shown below for Wheel Torque Requirements.
- The tightening of the fasteners should be done in stages. Following the recommended sequence, tighten fasteners per Wheel Torque Requirements shown below.
- Wheel nuts/bolts should be torque before first road use and after each wheel removal.



IMPORTANT! Check and re-torque after the first 16, 40 and 80 KM, (25 miles and again at 50 miles.) Check periodically thereafter.

Torque Requirement DO's:

- DO remove all oil and grease from threaded fasteners (studs and lugs).
- DO mask or shield (cover) all fastener contact surfaces (mounting surfaces and studs) before painting axles, whether for improved cosmetics or for corrosion protection.
- DO only use an impact wrench with torque stick as a tool initially to lightly secure the wheel, applying a criss-cross or star pattern. (See Figure 1)
- DO use a calibrated torque wrench to complete the torque fastening process applying the same criss-cross or star pattern. DO re-torque periodically during the trailer's initial towing and thereafter in accordance with the component supplier's recommendations.
- DO maintain records of the maintenance and torque checks performed by transporters, noting any loss of torque or any corrective measures taken.

Torque Requirement DON'Ts:

- DON'T deviate from the component manufacturers recommendations regarding compatible components without a competent engineering review.
- DON'T substitute any component for the component the suppliers have specified without a competent engineering review.
- DON'T deviate from the component suppliers fastener torque specifications, where provided, without a component engineering review.
- DON'T use adhesive products to maintain fastener retention.
- DON'T apply any additional paint on fastener contact surfaces (mounting surfaces/hub faces or studs)

To prevent the wheels from coming loose, the lug nuts and bolts must be tightened to the proper torque for the axle size on your trailer. You must use a torque wrench to obtain the proper tightening of the fasteners. If you do not have a torque wrench, use a lug wrench and then have the lug nuts tightened to the proper torque at a service garage. Over-tightening will result in breaking the studs.



Do not attempt to repair or modify a damaged wheel. Even minor modifications can cause a dangerous failure of the wheel and result in personal injury or death.

Axle, Hub and Bearing Assembly

Always inspect the axle hub before and after a long trip (2000 miles). Axle bearings must be inspected and lubricated once a year or every 3200 km to ensure safe and reliable operation. If a wheel bearing has been immersed in water it must be replaced. Trailers that are subject to extended period of non-use should have bearings inspected and repacked.

How to change or repack the wheel bearings

Tools required:

- Tire wrench
- Flat screwdriver
- Needle nose pliers
- 1-7/16" wrench or socket
- Wheel bearing grease

Removing the Wheel

- Loosen wheel nuts (Do not remove!).
- Support trailer with jack or jack stand so the wheel is off the ground.
- Remove wheel nuts and wheel.

Removing the bearings

- Remove the dust cap with a flat screwdriver.
- Remove the cotter pin
- Remove the axle castle nut
- Pull the hub off the axle
- Separate parts and clean before repacking with grease
- Check the bearing race for damage and replace if required.
- If the bearings exhibit flat spots on rollers, broken roller cages, rust or pitting, they must be replaced. Always replace bearings and cups in groups. The inner and outer bearings are to be replaced at the same time.
- Check seals for nicks, tears or wear. Replace damaged or worn seals. Re-install the Inner bearing and grease seal
- Pack the hub and bearings with high quality automotive wheel bearing grease. Re-install the outer bearing
- Re-install the castle nut; tighten nut and then back off nut 1/8 of a turn.
- Caution: DO NOT over tighten nut. The hub must turn freely and without play.
- Re-install the cotter pin and dust cap
- Re-attach wheel and nuts (Torque to 95 ft-lbs.)

Safe-T-Lube

Your axle is equipped with Safe-t-lube feature; the bearings can be periodically lubricated without removing the hubs from the axle. This feature consists of axle spindles that have been specially drilled and fitted with grease Zerk in the ends. When grease is pumped into the Zerk, it is channelled to the inner bearing then flows back to the outer bearing and eventually back out the grease cap hole.

The procedure is as follows:

- Remove the rubber plug from the end of the grease cap
- Place a standard grease gun onto the grease Zerk located in the end of the spindle. Make sure the grease gun nozzle is fully engaged on the fitting.
- Pump grease into the Zerk. The old, displaced grease will begin to flow back out of the cap around the grease gun nozzle.
- When the new, clean grease is observed, remove the grease gun, wipe off any excess, and replace the rubber plug in the cap.

Even with the Safe-T-Lube feature, periodic inspection and repacking must be done every 12 months or 12,000 miles. Do not pack hub full of grease. [Bearing Assembly Parts Breakdown](#)

Bearing Assembly Parts Breakdown

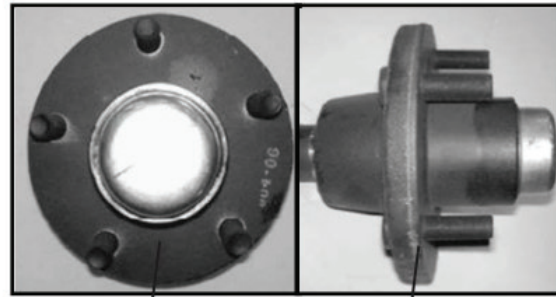
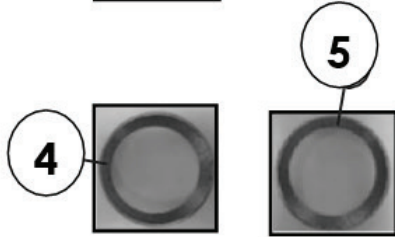
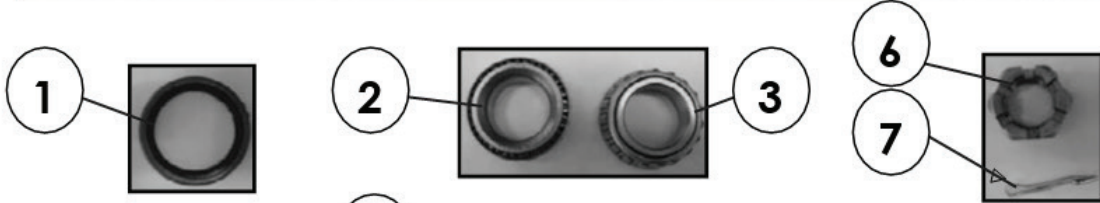
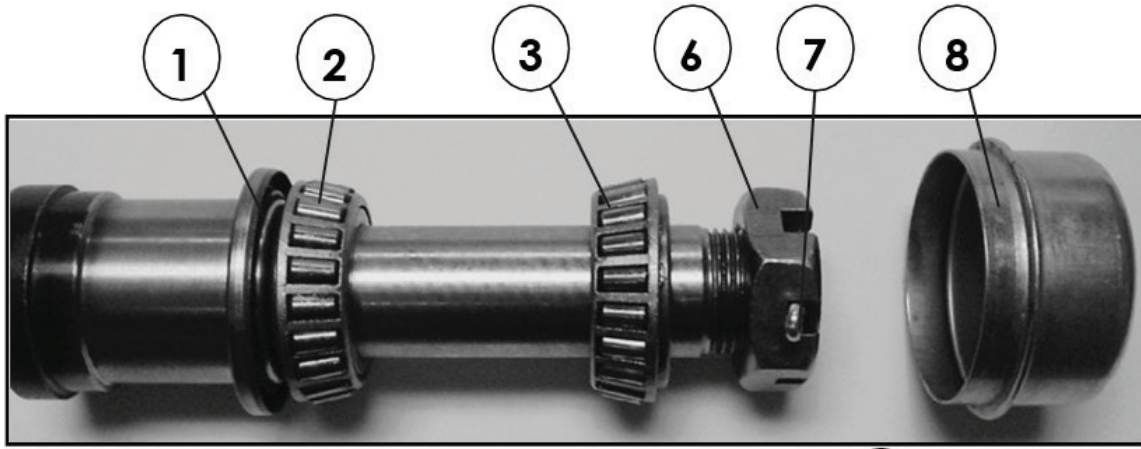

The bearing Race #4 is press fit into the hub and may not need to be / replaced when changing bearings

#	Part #	Description (1500 /2200 lbs. Axle)	Quantity
1	500829	Grease Seal (1-1/6")	2
2 & 3	500827	1-1/16" Bearing (inner and outer bearings)	4
4 & 5	500831	1-1/16" Race (inner and outer bearings)	4
6	501098	1-14 Slotted Jam Nut, 6 Slotted	2
7	501097	1/8" X 1 3/4" Cotter Pin	2
8	500970	Axle Dust Cap	2
9	500835	Wheel Hub (1500/2200 lbs. Axle)	2

Trailer Lights and Wiring

Before using the trailer, always perform a walk-around light inspection to make sure all lights function. You must connect the tow vehicle to the trailer and examine the turn signals, marker lights and brake lights. Also check for loose or damaged wires.



Failure to connect the tow vehicle lightning will result in non-functioning lights and may lead to collision.

The trailer is equipped with a 4-way flat connector. If your vehicle has a connector with more contacts or does not fit this plug you will need to purchase an adaptor from a local trailer hitch supplier. The trailer lights are sealed and the wires are protected for long lasting performance. If you have a problem with the lights or wiring it is important to be familiar with the wiring so you can determine the problem. Start by identifying the wires by colour and which operation they are connected to.

Below is a table that shows the wire by colour, location and operation it performs.

Wire Colour	Operation	Light Type	Wire Location
Green	Right Signal Brake ER Flasher	Stop/turn taillight	Passenger side (Right)
Yellow	Left Signal Brake ER Flasher	Stop/turn taillight	Driver's side (Left)
Brown	Running lights (Turn on headlights)	Amber marker light	Both sides of the frame (Front)
White	Trailer Ground	Grounding trailer	Chain bolt at the coupler

When looking for a lighting or wiring problem, always start by

- Checking that the bulb is not burnt out. You could do so, by simply switching the defective light with a functioning light on your trailer. If the light bulb needs to be replaced the whole assembly will need to be replaced.
- Checking over the trailer and the towing vehicle for any loose or damaged wires or connections.
- Checking to see if the connectors behind the light have come loose, you will need to remove them from the light pockets.
- Did a fuse on the vehicle blow? If so check the trailer wire related to the operation which caused the fuse to blow before you replace the fuse. A bare, stripped or pinched wire can cause a short in the trailer, which will cause the vehicle fuse to blow.

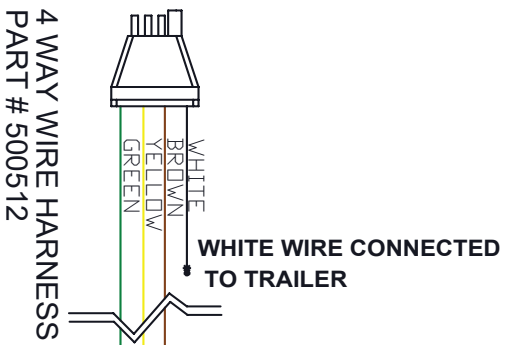

AMBER MARKER LIGHT
PART # 500515

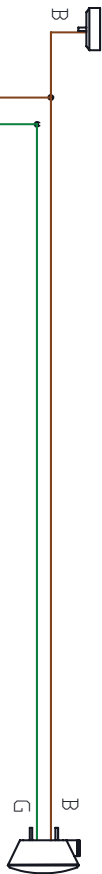

STOP/TURN LIGHT
PART # 500514

KIT TRAILER WIRING HARNESS

- 4'X4' TRAILER (PART # 504513)
- 4'X6' TRAILER (PART # 504513)
- 4'X8' TRAILER (PART # 504513)
- 5'X8' TRAILER (PART # 504513)

AMBER MARKER LIGHT
PART # 500515

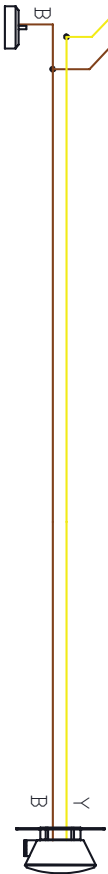

STOP/TURN LIGHT
PART # 500513
LICENSE PLATE HOLDER
PART # 500516

ONE YEAR LIMITED WARRANTY

This limited warranty is extended to the original purchaser of the trailer and designed for residential use only.

Westbrook Greenhouse Systems Ltd. (Westbrook) warrants that each trailer operated by the original purchaser under normal use in the continental United States or Canada will be free from defects in materials and workmanship for one year following the original purchase, subject to the requirements, exclusions and limitations stated below. The obligation of this warranty shall be limited to repairing or replacing any part or parts, which in the opinion of the factory are defective in materials or workmanship under normal use and service during the warranty period commencing with the date of the first retail purchase.

YOU MUST SEND US / RECORD YOUR PURCHASE

In order to validate this Limited Warranty, a warranty page has been provided to document your purchase and should be mailed to Westbrook no later than thirty (30) days following the purchase of your trailer.

ONE YEAR LIMITED WARRANTY

Subject to the requirements, exclusions and limitations stated below, the structure of your Trailer is warranted to the original retail purchaser against defects in materials and workmanship from normal use for one (1) year from the date of purchase. The structure is that portion of the trailer, which includes the main frame, consisting of the bottom rails, cross members, side posts and exterior walls, and the sub-frame, excluding the floorboards and running gear.

Subject to the requirements, exclusions and limitations stated below, all other components (electrical, lights, and couplers) of your trailer are warranted to the original retail purchaser against any defect in the materials and workmanship arising from normal use for one (1) year from the date of purchase.

EXCLUSION OF ITEMS WARRANTED BY OTHER MANUFACTURERS

Expressly excluded from the Limited Warranty are any claims related to items that are warranted by their manufacturer. These items include, but are not limited to: tires, rims, axles, and axle components including, without implied limitation, to win/tow out and camber on axle; brake components; springs and suspension components; couplers and jacks; and any other items purchased and installed by Westbrook. Any claims related to these items must be presented to their manufacturer for adjustment. Subject to the other terms of this Limited Warranty, Westbrook warrants proper installation of the above listed items.

OTHER EXCLUSIONS NOT COVERED BY THIS LIMITED WARRANTY

This Limited Warranty covers only defects in original components which arise from normal use and does not apply if the trailer has been subject to negligence, accident, abuse, misuse, improper loading or has been repaired or altered without the prior written consent of Westbrook. Damages caused by failure to provide proper maintenance and repair, loose or improperly torque lug nuts, use of incorrect or altered hitch ball or improper latching or loose nuts, bolts and screws (maintaining necessary tightness is the owner's responsibility) are not covered by this Limited Warranty.

In addition to the above exclusions, Westbrook expressly excludes from this Limited Warranty the following: tow vehicle wiring, replacement and work performed or options installed by others; deterior-

ation of paint and appearance due to use and exposure; loss of time, inconvenience, loss of use of trailer, rental of substitute equipment, loss of revenues, or other commercial loss; and tow vehicle wear. The trailer covered by this Limited Warranty is designed to be towed by a vehicle with up to one (1) ton capacity and any use of the trailer that exceeds the tow vehicle manufacturer's specific limitations are not covered by this Limited Warranty.

FINISH

Westbrook finish is consistent with industry standards. Due to the harsh nature and environment to which this finish is subjected (road debris, rocks, salt, and sand) behind motor vehicles and highway use, finish is not covered by this warranty.

PRIOR WRITTEN CONSENT REQUIRED

No reimbursement will be made to any dealer or owner for repairs made without the prior written consent of Westbrook. Any defective part(s) must be sent by prepaid freight to Westbrook in order to qualify for replacement or reimbursement under this Limited Warranty.

LIMITATION

Westbrook responsibility under this limited warranty shall be limited to repair or replacement of parts at the Westbrook factory, or for a reasonable allowance, at another place approved in writing by Westbrook. If such warranty fails because attempts at repair are not completed within a reasonable time, or it fails for any other reason, any damages are limited to the lesser of either the cost of needed repairs or reduction in the market value of the trailer caused by lack of repairs.

DISCLAIMER

This warranty is expressly in lieu of any other warranty not expressly provided herein which but for this provision might arise by operation of law, including any express warranties made outside this limited warranty, implied warranties of merchantability, implied warranties of fitness for a particular purpose, and any remedy for breach of contract. These warranties are hereby expressly excluded and disclaimed. If they cannot be disclaimed, any implied warranties of merchantability and fitness for particular purpose are expressly limited to a term of one (1) year, unless any applicable state law provides otherwise. Under no circumstances shall Westbrook be liable to purchaser or any other person for any special, incidental or consequential damages, whether arising out of breach of warranty, breach of contract, tort or otherwise, unless any state law provides otherwise. No one, including authorized Westbrook Dealers, is authorized to make further or additional warranties on behalf of Westbrook. Authorized repairs do not extend the terms of this limited warranty. This warranty is not transferable from the original owners.

Westbrook Trailer Ltd.
4635 Durham Road,
Beamsville, Ontario, L3J 1R3

www.westbrooktrailers.com

Warranty and Registration

How to obtain service

If you need to file a claim under the guidelines of our warranty please do not call or return the trailer to the store from which it was purchased. This may delay the time it takes to get service or parts. Contact us directly at 1-866-857-1445 or email us at support@westbrooktrailers.com We will be happy to assist you. Please note that if you haven't registered your trailer's warranty, you will need to do so.

When contacting us, you should have the following information readily available:

- VIN number of the trailer (17 Digit vehicle identification number)
- Proof of purchase from an authorized dealer
- Description of the problem
- Conditions relating to the problem (weather, highway, etc)
- Prior repair history

Register the Warranty

- **Go online at :**
 - <https://www.westbrooktrailers.com/owners-info/warranty/>
- **Contact us:** 1-866-857-1445
- Send us the information requested on the registration form on p. 32 at **support@westbrooktrailers.com**
 - Fill out the Warranty Registration form on p. 32 and
 - **Mail it to:**
Westbrook Trailer Ltd.
4635 Durham Road,
Beamsville, Ontario,
L3J 1R3

Warranty Registration Form

Name		Trailer Model	
Address		Trailer Size	
City		Purchase Date	
Province/State		Purchase At	
Postal Code/Zip Code		City	
Phone Number		Province/State	
Email			

Trailer VIN # (Vehicle Identification Number) located on the VIN decal at the front driver side panel.

VIN #																			
	2	S	S	U	B	1	1	A											

Please answer the following questions:

Are you aware that the maximum tongue weight must not exceed 10% of the trailer GVW?

(For more information refer to loading the trailer section)

Yes No

Are you aware that when loading cargo the weight should be distributed evenly over the axle?

(For more information refer to Loading Cargo section)

Yes No

Are you aware that the axle bearings must be inspected and lubricated at least once a year or every 3200 KM?

For more information refer to Axle, Hub and Bearing section

Yes No

Westbrook Trailer Ltd.

4635 Durham road,

Beamsville, Ontario,

L3J 1R3

Kit Trailer Accessories

Accessoires pour Remorque en Kit

Quality, Performance, Flexibility
The New Generation of Load Adaptive Trailers



Tongue Jack
Vérin



Ramps Kit
Kit rampes



Spare Tire kit
Kit de pneu de secours



Tongue Extension
Extension de la langue



Rail side for 8" & 12" tire
Côté rail pour pneu de 8" et 12"

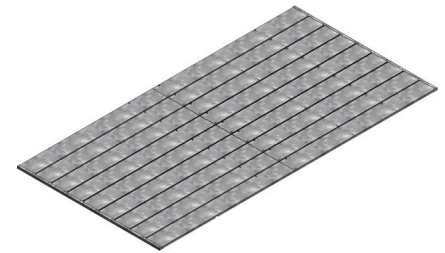

Floor kit
Kit de plancher

4635 Durham Road,
Beamsville, Ontario, Canada L3J 1R3
Toll Free/Sans Frais: 1-866-857-1445
Email: support@westbrooktrailers.com
www.westbrooktrailers.com

Qualité, performance, polyvalence
La nouvelle génération de remorques
s'adaptant à sa charge